

OWNER'S MANUAL



Avalon Marine Propane Barbeque Grill Model A10-1224



For questions regarding performance, assembly, operation, parts, or returns, contact the experts at MAGMA by calling TOLL FREE IN U.S.A. AND CANADA **1-800-86-MAGMA**

7:00 a.m. - 5:00 p.m. Pacific Time Monday thru Friday or e-mail us at magmamail@aol.com



Read all instructions before operating. Save manual for future reference.

IMPORTANT SAFETY WARNINGS

READ ALL INSTRUCTIONS BEFORE OPERATING.

- USE OUTDOORS ONLY.
- DO NOT USE THIS APPLIANCE INSIDE THE BOAT OR ANY ENCLOSED SPACE.
- BBQ's RADIATE HEAT. CLEARANCE FROM COMBUSTIBLES, 24" SIDES AND BACK. NEVER USE UNDER AWNINGS, PATIO COVERS, ETC.
- USE PROPANE GAS ONLY. FUEL STORAGE SHOULD BE IN COMPLIANCE WITH THE AMERICAN BOAT AND YACHT COUNCIL (ABYC) STANDARDS A-1 (9), MARINE LIQUIFIED PETROLEUM GAS (LPG) SYSTEMS.
- FOR NATURAL GAS APPLICATION CONTACT MAGMA.
- ALWAYS LIGHT BBQ WITH LID OPEN.
- NEVER LEAVE HOT BARBECUE UNATTENDED.
- USE HOT PAD WHEN HANDLING.
- ALWAYS TURN BBQ OFF AFTER USE.

FEATURES

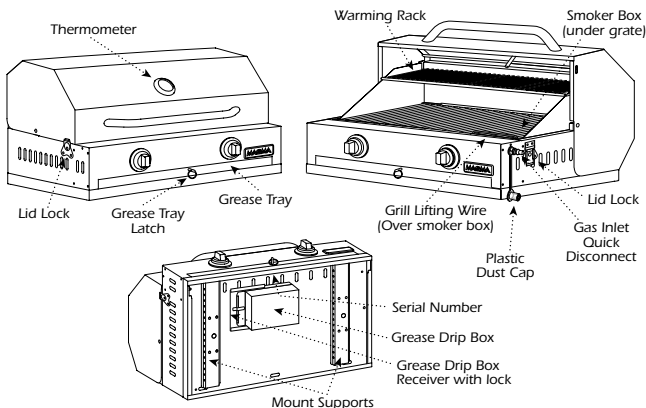

INSTALLATION INSTRUCTIONS

The Avalon can be used with "On-Board", pre-regulated, low-pressure (1/2 PSI), LPG systems, or with LPG disposable 1 lb. canisters (DOT-39 NRC 228/286).

Complete installation requires either Magma A10-1210 Quick Disconnect for On-Board LPG Systems, or Magma A10-1207 Quick Disconnect Canister Kit (see below).

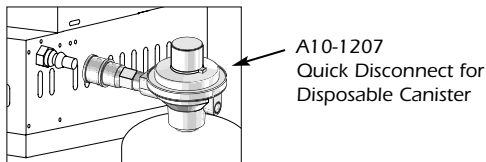
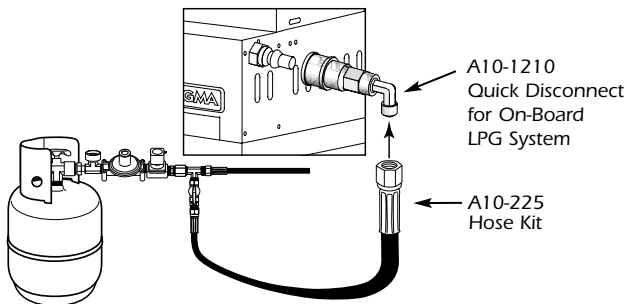

ATTACHING QUICK DISCONNECT FITTING TO BBQ

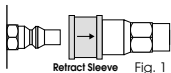

To connect-
retract sleeve of socket.
(Fig. 1)

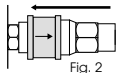

Insert gas inlet
(Fig. 2)

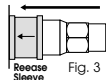

Release sleeve and push
socket until sleeve snaps
forward locking gas inlet
in socket (Fig. 3)

OPERATING PROCEDURES

- OPERATE ONLY ON LOW WHEN LID IS CLOSED.**
- ALWAYS OPERATE WITH SMOKER BOX IN PLACE.**
- ALWAYS OPERATE WITH GREASE TRAY & GREASE DRIP BOX WITH FOIL LINER IN PLACE.**
- ALWAYS COVER FUEL INLET WITH DUST CAP TO PREVENT OBSTRUCTION FROM DEBRIS OR SPIDER WEBS WHEN NOT IN USE.**

WARNING: Do not overheat barbecue. Stainless Steel loses anti-corrosive characteristics when subjected to extreme heat. Stainless Steel parts were made to fit closely to reduce on-board rattle; extreme heat will cause parts to expand and tighten in place. If medium or high heat is required, grill with lid open.

LIGHTING INSTRUCTIONS

- Open lid during lighting.
- Push and turn knob slowly counter-clockwise to high position. If unit does not ignite, return knob to off position and repeat.
- Visually confirm ignition. Look through hole to verify flame. (see Illustration)
- Turn knob to adjust flame.

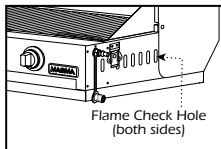

TO REDUCE FLARE-UP

- Trim excess fats from meat.
- Use non-oil based marinades.
- Reduce heat or use one burner only.
- Use water spray directly on flare-ups.
- Cook only on low with lid on.

USE OF GREASE TRAY & GREASE DRIP BOX ALWAYS LEAVE GREASE TRAY & GREASE DRIP BOX WITH LINER IN PLACE WHEN OPERATING.

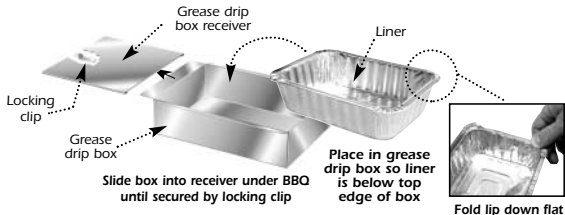

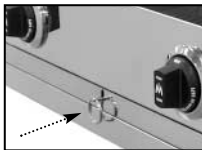

Lift up on ring to unlock grease tray



Pull out to clean only after
BBQ is cold

ADJUSTMENT OF SPARK

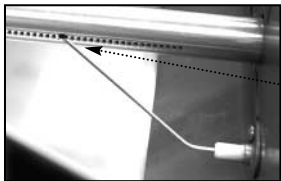

CAUTION: Spark can cause small shock. Do not leave fingers on or near igniter wire while engaging spark.

- Bend electrode wire approximately 3/16 to 1/8" from large hole in burner.

CORRECT PLACEMENT OF GRILL GRATES

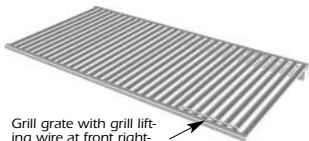

Grill grate with grill lifting wire at front right-over the smoker box

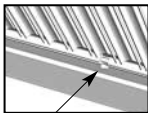

Screw head will match slot in the bottom rod of grill grate

USING SMOKER BOX ALWAYS OPERATE WITH SMOKER BOX IN PLACE.

Wood chips must be soaked in water prior to use, per wood chip manufacturer's instructions.

- Lift far right grill grate by placing spatula blade under the grill lifting wire to expose the smoker box.
- Fill box with chips and replace grate.
- Use the right burner on low temperature to smoke wood chips.

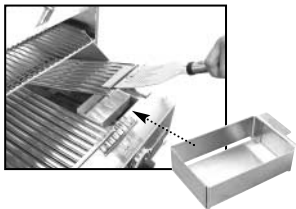

MAINTENANCE

ALWAYS COVER FUEL INLET WITH DUST CAP TO PREVENT OBSTRUCTION FROM DEBRIS OR SPIDER WEBS WHEN NOT IN USE.

A WORD ABOUT STAINLESS STEEL

Stainless steel exposed to high heat for prolonged periods will change in color and texture. The radiant plates and other internal parts, used to distribute heat evenly across the grill, do so by deflecting high heat over a large surface area. This prolonged exposure to high temperature will cause the plates to change color. This “bluing” and later “browning” is normal and will not affect the product operation.

Exterior Stainless Steel Components

We recommend that you clean grill after each use. Use soapy water with a soft cloth or sponge. Rinse with fresh water and dry. We also recommend that you cover the grill between uses. Optional covers are available from your retailer or directly from Magma.

Interior Stainless Steel Components

We recommend cleaning after each use. Oven/Grill Cleaner is recommended to remove burnt-on residue.

Igniter Electrode

The igniter electrode, located just beside the burner, should be kept clean of all grease and debris. Wipe it clean with a soft cloth. Care should be taken not to damage the ceramic insulation, spark electrode or bend the electrode wire during this process.

Grill Grates

We recommend that you clean the grill grates with a brass wire brush while the grill is warm. They can then be washed by hand as required. Oven/Grill Cleaner is recommended to remove burnt-on residue.

Control Valves

The valves were adjusted, set, and tested at the factory. You should not attempt to adjust the valves. Call MAGMA if you suspect that your valve is not properly adjusted.

Removal and Cleaning the Burner Tubes



1. Lift burner out of bracket.



2. Rotate burner.



3. Lift and pull.



4. Remove.

- Inspect burners, remove debris or spider webs.
- Inspect valve orifice while burner is removed, clean if needed.
- To re-install, reverse the removal procedure above, be sure brass orifice is centered in burner tube.

TROUBLE SHOOTING GUIDE

Problem	Possible Cause	Possible Solution
Burner will not light with igniter	Igniter electrode covered with grease or residue	Clean igniter electrode
	Igniter/electrode too far from burner	Adjust electrode until proper spark appears (see page 5)
	Igniter/electrode wire loose or disconnected	Call Magma
	Wire is shorted causing spark from wire before electrode	Call Magma
	No spark being generated	Call Magma
Burner will not light even with match	No gas flow	Check fuel level, refill cylinder or replace canister
	Obstructed gas flow/debris or spider webs in burner tube	Clean valve orifice and burner, check all lines (see page 6)
Flare-up	Excessive cooking temperature	Operate only on low when lid is closed Reduce flame level Leave lid open Turn off one burner Use water spray to cool
	Grease and/or residue build-up	Clean components
	Excessive fat in meats	Trim fat from cuts of meat before grilling
	Excessive oils in marinades	Use non-oil based marinades
Yellow sooty flame	Obstructed gas flow/debris or spider webs in burner tube	Check and clean valve orifice and burner. Check gas supply lines (see page 6)

LIMITED WARRANTY

Magma Products, Inc. guarantees the Avalon gas grill to be free from defects in materials or workmanship to the original consumer. This guarantee is for the periods herein specified when used under normal and reasonable conditions, one (1) year from the date of original purchase. This warranty does not include the cost of property damage or any inconvenience due to the failure of the product. Nor does it cover damage due to misuse, abuse, accident, or damage resulting from transportation of the product. Nor does it include damage resulting from the commercial use of this product. If the product fails to operate due to a defect in materials or workmanship during the warranty period, the defective part will be repaired or replaced at Magma's option. If you wish to obtain performance under this limited warranty, you should contact Magma's Customer Service Department via telephone at 562-627-0500 or 800-86-MAGMA, or via e-mail at magmamail@aol.com, or via U.S. Postal Service mail at "Magma Products, Inc., attention Customer Service, 3940 Pixie Ave. Lakewood, CA, 90712." The defective part, along with proof of purchase, must be returned postage prepaid to Magma Products, Inc. We suggest that you keep your purchase receipt as we may require reasonable proof of purchase.

In the state of California only, if refinishing or replacement of the product is not commercially practicable, the retailer selling the product, or Magma Products, Inc., will refund the purchase price paid for the product, less the amount directly attributable to use by the original consumer prior to the discovery of the nonconformity. In addition, in the state of California only, you may take the product to the retail establishment from which it was purchased or to any retail establishment selling this product in order to obtain performance under this warranty.

All implied warranties, including the implied warranties of merchantability and fitness for a particular purpose, are limited in duration to the express warranty periods specified herein for the parts described herein.

Some states do not allow limitations on how long an implied warranty lasts, so the above limitation may not apply to you. Neither Magma dealers, nor the retail establishment selling this product has any authority to make any warranties or to promise remedies in addition to or inconsistent with those stated above. Magma's maximum liability shall not exceed the purchase price of the product paid by the original consumer. Some states do not allow the exclusion or limitation of incidental or consequential damages, so the above limitation or exclusions may not apply to you. The warranty gives you specific legal rights and you may also have other rights which vary from state to state.

MAGMA and the Magma logo are registered trademarks of Magma Products, Inc.
Avalon is a trademark of Magma Products, Inc.
Patent pending.

CALIFORNIA PROPOSITION 65 – WARNING – The burning of gas cooking fuel generates some by-products, which are on the list of substances, which are known by the State of California to cause cancer or reproductive harm. California law requires businesses to warn customers of potential exposure to such substances. To minimize exposure to these substances, always operate this unit according to the use and care manual, ensuring you provide good ventilation when cooking with gas.



Magma Products, Inc.

3940 Pixie Avenue, Lakewood, CA 90712 ■ USA
Phone (562) 627-0500 ■ e-mail magmamail@aol.com
Website: www.magmaproducts.com